



ELECTRIC CHAIN HOIST

Available in 1T, 2T, 3T & 5T for various industrial & mining applications

Complies with the Machinery Directive 2006/42/EC.

- Overload protection - Externally adjustable slip clutch
- Robust steel housing
- Housing protection IP 55
- Control protection IP 65
- Duty cycle I Starts per hour 40% I 240
- Insulation class F
- Classification M512m (ISOIFEM)
- Operating temperature -20°C - +40°C
- Brake- Electromagnetic spring pressure brake, holds the load in the event of power failure
- Limit switch - Electro-mechanical upper and lower limit switch
- Thermal protection- Protected through heat sensor
- Swivel load hook with safety latch
- Easy to disassemble for maintenance purposes
- Permanently lubricated transmission, ensures smooth and quiet operation
- Supplied with 48V Pendant control with emergency stop
- Suitable for a wide range of industrial applications
- Supplied with test certificate
- **Factor of Safety 4:1**



OVERLOAD PROTECTION & SLIP CLUTCH

Product Code	Capacity (ton)	Lifting Speed M/min	Load Chain		Power Output (kW)	Net Weight (kg)	Extra Weight kg/m
			Diameter (mm)	No. of Falls			
PHU010S380	1	5.0	8 x 24	1	1.1	45	1.5
PHU020S380	2	5.3	10 x 30	1	3.6	94	2.2
PHU0202FS380	2	2.5	8 x 24	2	1.1	51	3.0
PHU030S380	3	6.0	11.2 x 34	1	3.0	94	2.7
PHU050S380	5	3.0	11.2 x 34	2	3.0	108	5.4

CAUTION!



Always read the instruction manual before use

Always wear the correct safety gear

PRO HOIST



ELECTRIC CHAIN HOIST & MOTORISED TROLLEY

Available in 1T, 2T, 3T & 5T for various industrial & mining applications

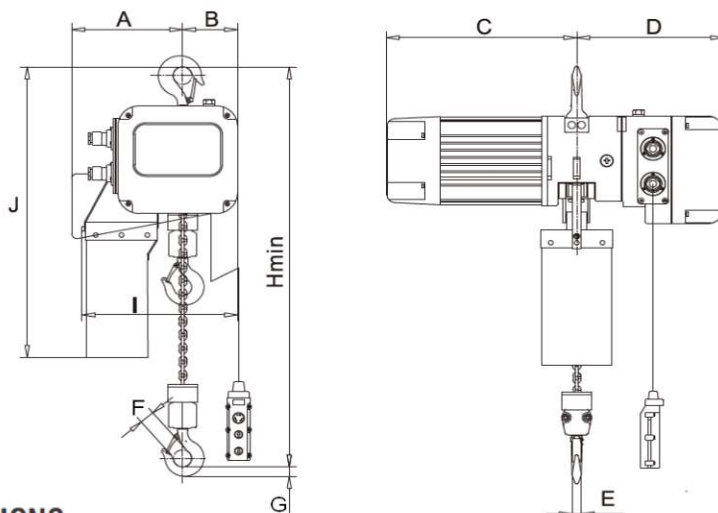

HOIST DIMENSIONS

Product Code	Capacity (ton)	Lifting Speed m/min	Load Chain Falls	A	B	C	D	E	F	G	H	I	J
PHU010S380	1	5	1	200	102	302	307	20	31	25	460	295	630
PHU020FS380	2	2.5	2	243	59	302	307	27	38	43	700	295	690
PHU020S380	2	6.6	1	243	165	358	336	27	38	43	640	460	780
PHT030S380	3	6	1	243	165	358	336	27	38	43	640	460	780
PHT050S380	5	3	2	298	110	358	336	35	52	51	910	460	870

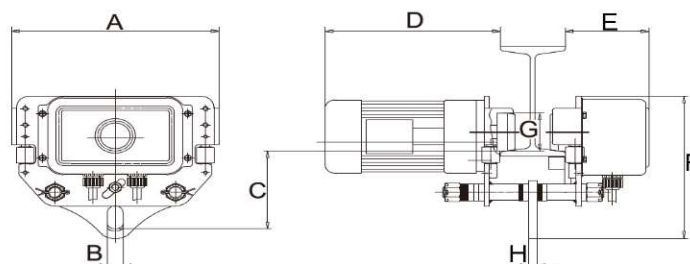

MOTORISED TROLLEY DIMENSIONS

Product Code	Capacity (ton)	Min. Radius (mm)	Wheel \varnothing G (mm)	Beam Flange (mm)	A	B	C	D	E	F	H
PHT010S380	1	1.5	68	74-140	340	24	145	290	130	260	14
PHT020S380	2	2	75	74-140	340	30	140	315	132	280	14
PHT030S380	3	2	96	100-170	370	36	210	319	135	340	16
PHT050S380	5	2	110	100-170	410	40	205	359	135	345	20



FACTOR OF SAFETY 4:1

CAUTION!



Always read the instruction manual before use
Always wear the correct safety gear